

MARTIN® E-Z™ Pneumatic Vibratory Gaylord Tilter

The Martin® E-Z™ Pneumatic Vibratory Gaylord Tilter is designed to assist in the vacuum unloading of gaylord containers. The automatic tilting feature allows complete removal of material from the container with little or no assistance from your operator.

The adjustable regulator permits setting initial lift at any desired weight. This unit will lift 1000# with only 100 psi. air pressure! Normal operation is to begin tilting action when the box is around half empty. Martin™ Tilt Tables are durable and easy to maintain. We use heavy duty pillow block bearings to ensure smooth controlled pivoting. Our ten-gauge top deck is reinforced with structural steel to make it durable enough to withstand years of abuse.

These units will reduce labor cost by freeing your operator from tending his raw material flow. They also reduce material waste with the effortless, complete emptying of your container.

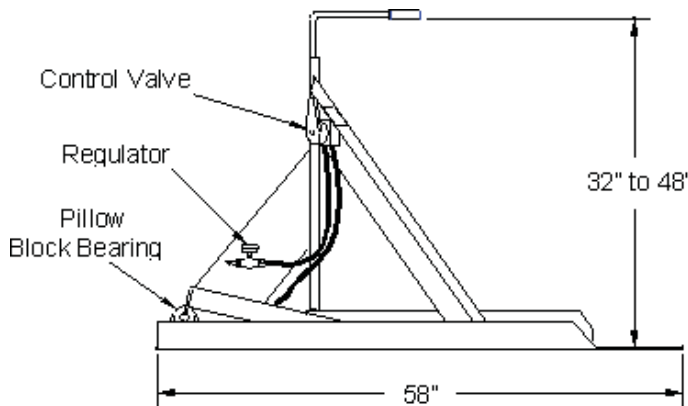
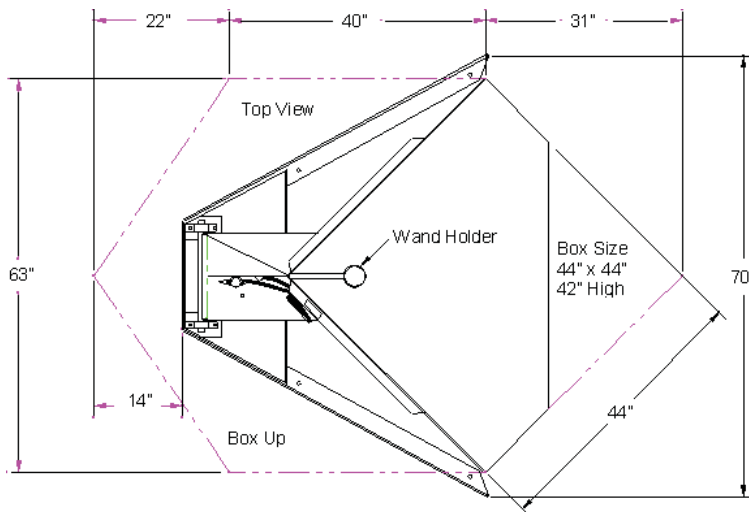

Standard Features:

- Automatic or Manual Tilt Action
- Hand Lever Controlled
- Flow Control to adjust Operating Speed
- 7 Gauge Steel Deck
- Adjustable Height Vacuum Wand Holder
- 1" Pillow Block Pivot Bearings
- Double Convuluted Industrial Air Bag
- 45 Degree Tilt Angle

Optional Features:

- Foot Pedal Control Valve
- Efficient Pneumatic Vibrator with Controls

Lift Capacity Chart

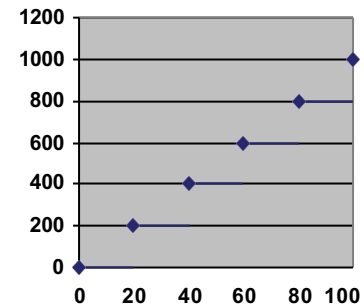

Air pressure required for initial lift