

# **OWNER'S & OPERATOR'S MANUAL**

## **MT-FAST™ Dry Bulk Trailer Vibrator**

---

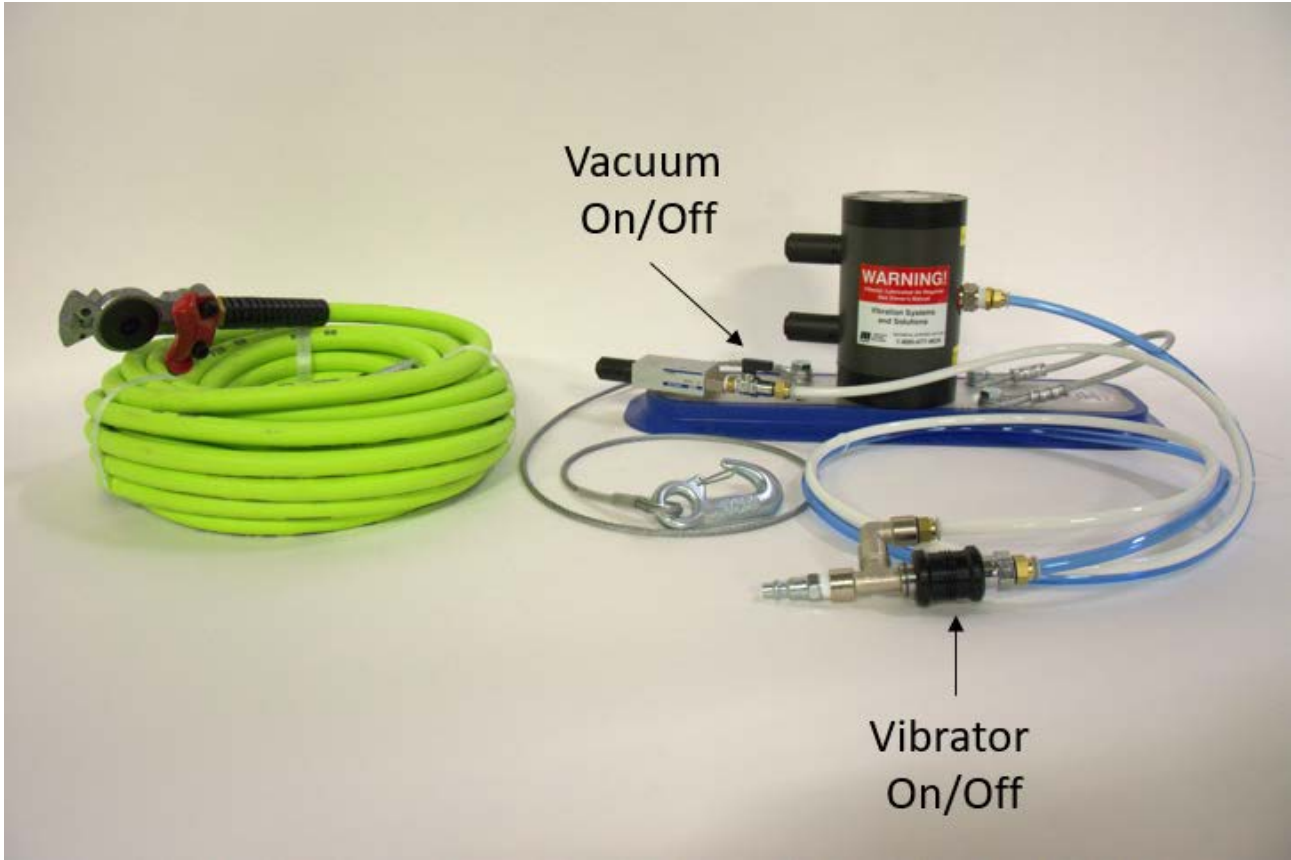

## **DESCRIPTION**

MT-FAST™ Portable Vibrators are used for quick fastening of pneumatic vibrators on trailers.

1. Ideal for applications in which vibrators cannot be permanently mounted or if frequent repositioning is necessary.
2. Operated with compressed air with a pressure of 45-90 psi (3 to 6 bar).
3. Suitable for use in explosive and wet environments.
4. Designed to operate from the air supplied by the air compressor located on the power unit.

### **Maximum operating pressure:**

The maximum operating pressure must not exceed 100 psi (7 bar).

### **Permitted operating conditions:**

During operation the temperature must not exceed or fall below the permitted range of 14F to 158F (-10°C to 70°C). ***The vibrator must be stored in a warm area (+45F) when not in use.***

### **Functional Unit**

The combination of hose set, vac base and vibrator is a functional unit. The vibrator is fixed to the vac base. The vac base consists of a 2-way on/off valve, a venturi and the pneumatic clamp pad. When the 2-way valve is opened and compressed air is supplied to the venturi generating a vacuum. The vacuum connects the MT-FAST™ to the trailer. The valve controlling the vacuum is located on venturi assembly. If suction is reduced, change 1/4" Muffler (number 19), on a monthly basis it is good to blow air in the exhaust port on vacuum (number 11) to purge any fugitive material that may have been ingested.

### **Hose Set**

The hose set connects the energy supply to the vibrator and the vac base. A 3-way control valve is supplied. The vibrator is operated with the 3-way control valve. The vibrator control valve is a slide type valve.

### **Vibrator.**

The vibrator is a non impacting linear vibrator that is specially designed for trailer vibration. (*Care must be taken to clean the glad hand fittings so that dirt not be allowed to enter the vibrator*). Be sure to never operate vibrator without both mufflers (number 2) installed and in good working order.

### **Operation**

1. Attach the 50' air supply line to the air supply of the power unit, using care not to allow dirt in the line.
2. Attach the MT-FAST hose assembly to the air supply line.
3. Activate the vacuum by rotating the blue handle valve (number 4) located on the vacuum nozzle.
4. Position the unit on the trailer where vibration is desired.
5. Activate the vibration by sliding the vibrator control valve totally forward.
6. The unit can be moved any where on the trailer hopper by deactivating the vibrator, deactivating the vacuum and repeating steps 3-5.

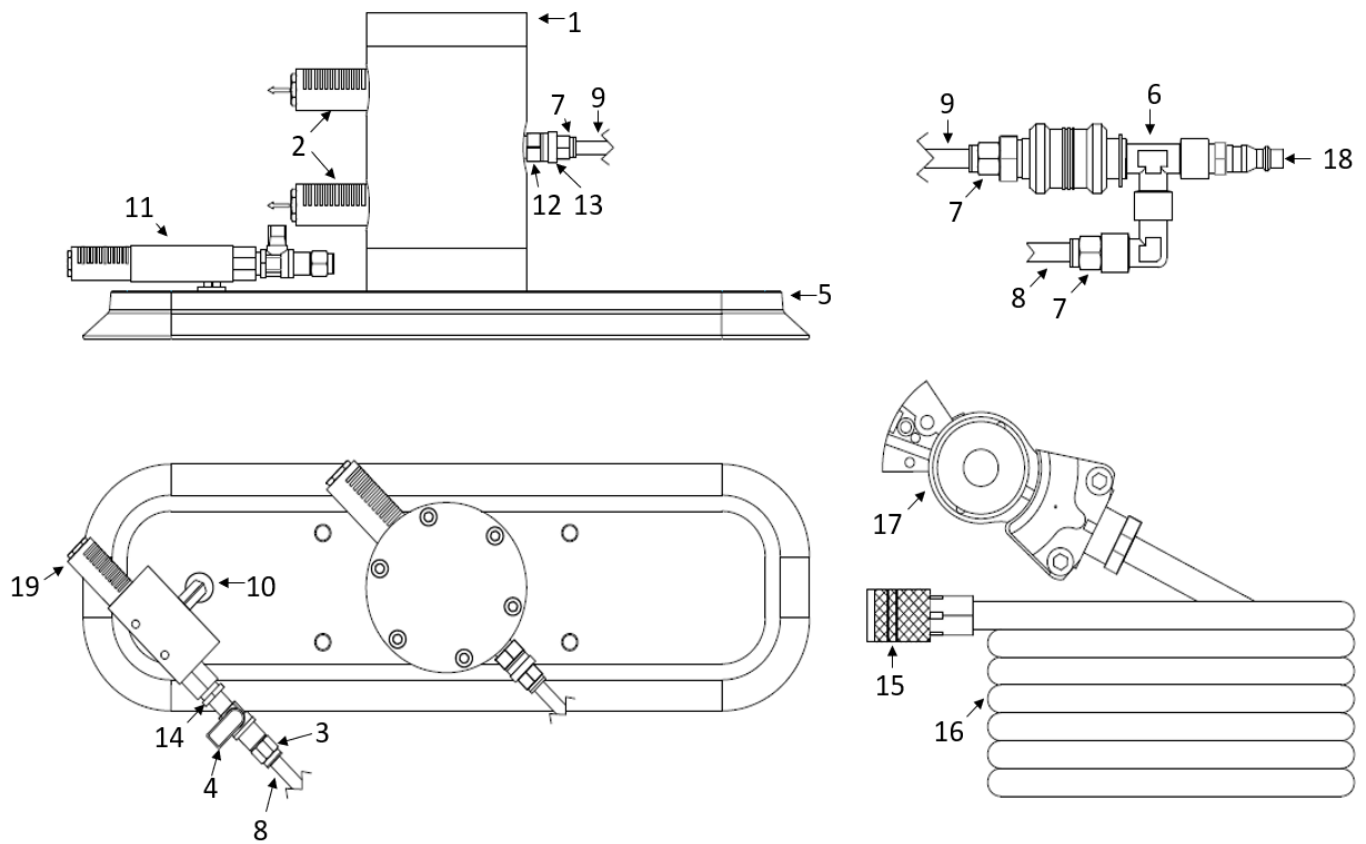

Position	Part Number	Description	Qty
1	32604-RB	NTS 54/02 ROUND BASE	1.00
2	89001375	3/8 NETTER MUFFLER	2.00
3	KQ2H08-U01	1/8" UNI FIT CONNECTOR	1.00
4	61700390	VAC 10 VALVE	1.00
5	98618001	VACUUM PAD	1.00
6	88604910	VAC 10 HOSE SET	1.00
7	KQ2H08-U02	1/4" UNI FIT CONNECTOR	3.00
8	TU0805W-20	WHITE TUBING	5.00
9	TU0805BU-20	BLUE TUBING	5.00
10	68606	3/8 x 1/4 90 MALE ELBOW BRASS	1.00
11	98604215	VACUUM NOZZLE	1.00
12	0443436	3/8 METRIC TO NPT ADAPTOR	1.00
13	424126	3/8 TO 1/4 BUSHING BRASS	1.00
14	P110DA	1/4 x 1/8 BRASS BUSHING	1.00
15	430117	1/4INDCPLR1/4NPT FEM	1.00
16	0431265	3/8" X 50" YLW AIRHOSE	1.00
17	5100006	1/2" FPT EMRGGLADHAND	1.00
18	430017	1/4INDPLUG1/4NPT MALE	1.00
19	89001025	1/4 NETTER MUFFLER	1.00

**CAUTIONS**

- *Do not disconnect air supply before removing the unit from trailer.*
- *Do not vibrate with trap or valve closed. The load material will compact.*
- *Never operate vibrator without the 3/8" Netter muffler (number 2) installed*
- *Do not allow unit to be stored in less than 45F temperature.*

**PARTS, SERVICE AND TECHNICAL HELP.****CONTACT:****MARTIN VIBRATION SYSTEMS****990 DEGURSE AVE.****MARINE CITY, MI 48039****PHONE – 800-477-4634****TEXT – 810-305-9709****EMAIL – SALES@SHAKE-IT.COM**