

MARTIN® WHIRLWIND™ High-Frequency Turbine Vibrator

The unique urethane-encapsulated turbine in Martin Engineering's MARTIN® WHIRLWIND™ High-Frequency Turbine Vibrator produces more power with less noise than any other high-force/high-frequency pneumatic turbine vibrator.

With an output of over 10,000 lb-f, depending on the application, the MARTIN® WHIRLWIND™ High-Frequency Turbine Vibrator doubles the force output of the most powerful competitive models. Units mount easily to cradle lug brackets or rail car wedge brackets, and operate quietly to meet OSHA noise requirements.



FEATURES

Moves More Material

Larger unbalance creates greater force output to move your material.

Saves Your Hearing

Testing shows noise level from 6 to 10 dB less than competitive models and within OSHA noise limits.

One-Worker Portability

Built-in handle provides easy portability for use in railcar unloading or on pre-cast forms.

Reduces Maintenance Costs

Long-life, high-speed sealed bearings need no lubrication.

Concrete Consolidation

Allows fast placement and high-strength consolidation, and provides excellent surface finish.

Railcar Unloading

High-frequency and high-force provide efficient unloading of compacted fine powders.

MARTIN® WHIRLWIND™ High-Frequency Turbine Vibrator

DIMENSIONS

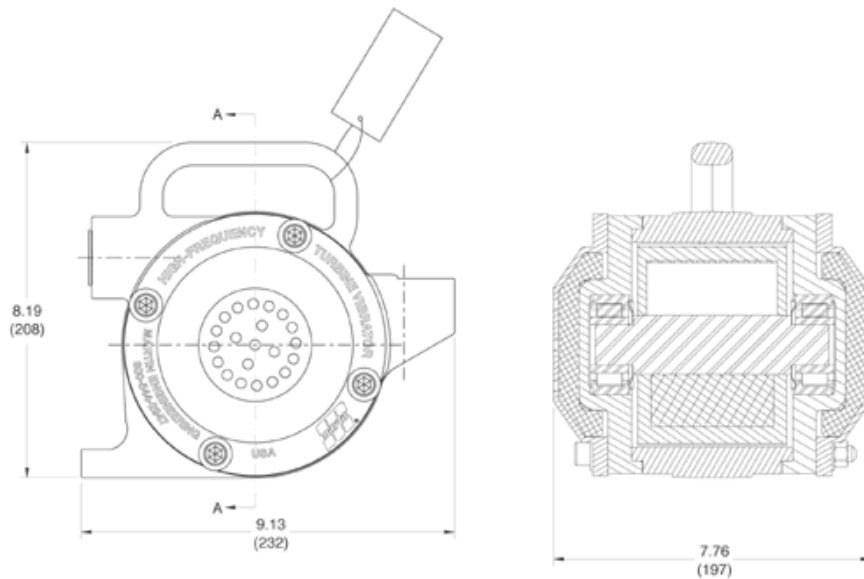

PERFORMANCE

WHIRLWIND PERFORMANCE DATA

FREQUENCY			FORCE OUTPUT LB-F			AIR		
40 psi	60 psi	80 psi	40 psi	60 psi	80 psi	40 psi	60 psi	80 psi
6500	8400	9300	5158	8615	10,560	21	25	28