

E-Z™ Vibratory Feeders

Powered by efficient pneumatic drives

MARTIN® E-Z™ Vibratory Feeders meet the needs of feeding applications up to 8 tph. The simple, all stainless steel fabrication is E-Z to clean, perfect for food, chemical and pharmaceutical applications. The drive and suspension components are designed to operate in hazardous or wet environments.

Units are available in various configurations:

1. Standard, “off-the-shelf” units.
2. Custom sizes.
3. Drive and suspension only.
4. Flat, vee or custom trays available.



FEATURES

Clean, Sanitary Design

Standard, all stainless steel fabrication, powered by a corrosion proof, coated drive. Ideal for food, chemical & pharmaceutical applications.

Explosion-Proof & Waterproof

No sparks or heat are generated by the pneumatic drive system. Totally sealed allowing vibratory feeders a safe wash-down.

Quiet & Energy-Efficient

Drive system operates at less than 65 dBA.
Uses 0.18 – 3.14 cfm.

Exact Adjustment

Speed and stroke are independently adjusted, providing exact control.

3-Year Guarantee

Drive unit is covered by a full 3-year guarantee.

On-Site Feeder Testing

Call us to test the E-Z™ Feeder System at your location.

E-Z™ Vibratory Feeders

DIMENSIONS

	A	B	C	D	E	F	G	AIR CONSUMPTION CFM (L/MIN)	
								30PSI(2BAR)	60PSI(4.1BAR)
EZ 2 4X24	24(610)	4(102)	2(51)	8.25(210)	6.75(171)	2(51)	12(305)	.49(14)	1.25(57)
EZ 2 3X18	18(457)	3(76)	2(51)	8.25(210)	6.75(171)	2(51)	6(152)		
EZ 2 6X20	20(508)	6(152)	2(51)	8.25(210)	6.75(171)	2(51)	8(203)		
DRIVE ONLY	10.13(257)	3(76)	N/A	8.25(210)	6.75(171)	2(51)	N/A		
EZ 4 5X24	24(610)	5(127)	2(51)	8.25(210)	6.75(171)	2(51)	12(305)	.71(20)	2.11(99)
EZ 4 6X18	18(457)	6(152)	2(51)	8.25(210)	6.75(171)	2(51)	6(152)		
EZ 4 7X20	20(508)	7(178)	2(51)	8.25(210)	6.75(171)	2(51)	8(203)		
DRIVE ONLY	10.13(257)	4(102)	N/A	8.25(210)	6.75(171)	2(51)	N/A		
EZ 8 6X36	36(914)	6(152)	3(76)	8.25(210)	6.75(171)	2(51)	24(610)	.92(26)	2.4(110)
EZ 8 8X30	30(762)	8(203)	3(76)	8.25(210)	6.75(171)	2(51)	18(457)		
EZ 8 12X24	24(610)	12(305)	3(76)	8.25(210)	6.75(171)	2(51)	12(305)		
DRIVE ONLY	10.13(257)	6(152)	N/A	8.25(210)	6.75(171)	2(51)	N/A		

inches (mm) Standard sizes listed above. Call 1-800-477-4634 for special configurations.

E-Z™ FEEDER DIMENSIONS

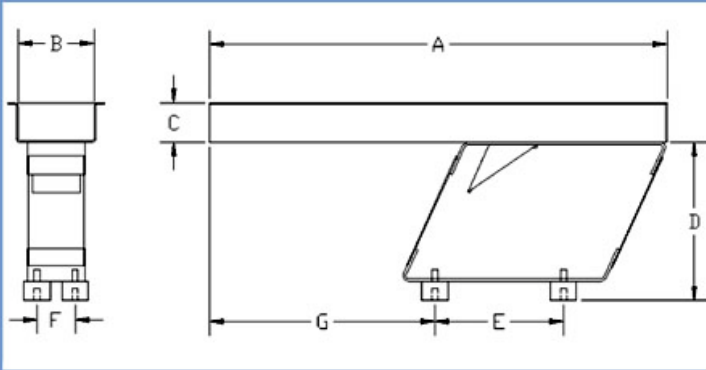

E-Z™ DRIVE ONLY

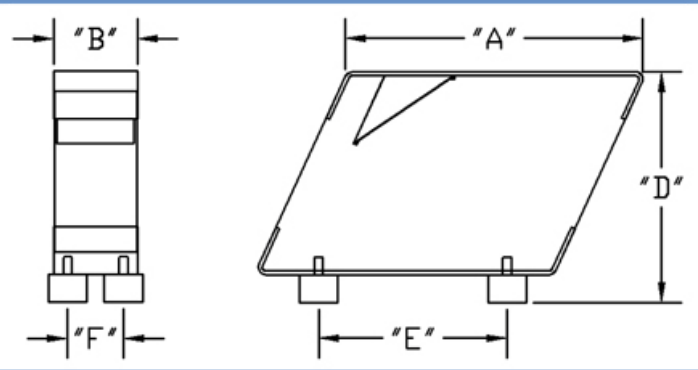

PHOTOS



MARTIN® E-Z™ Feeder



MARTIN® E-Z™ Feeder