

## MARTIN® E-Z™ Dry Ingredient Spreader

The NEW E-Z™ Dry Ingredient Spreader applies dry ingredients, including seasonings, spices, chopped nuts and frozen foods to conveyed products accurately. Mounted directly above conveyors, product is metered directly on to baked goods or frozen entrees.

**Using the same proven technology as the MARTIN® E-Z™ FEEDER SYSTEM, consistent feed rates are guaranteed.** The powerful, energy efficient, pneumatic drive delivers what you need, where you need it and when you need it. The instant on, instant off operation insures exact metering with no wasted ingredients.

All E-Z™ Dry Topping Spreaders are fabricated from 304 S.S. and then electro polished, providing a sanitary design that is a snap to clean.



### FEATURES

#### Clean, Sanitary Design

Standard, all electro-polished 304 SS fabrication powered by a corrosion-proof, pneumatic drive. Cleaning and maintenance is simple compared to other dry topping machines.

#### Fast, Accurate Dispensing

Instant on, instant off.

#### Versatile Design

Installs directly above any conveyor from 6 to 36" wide. Please consult factory for sizes over 36."

### DIMENSIONS

A*	B*	C	D	E
Custom widths		15.5(393)	14.5(368)	1.75(44)
inches (mm)	*dependent on conveyor width			

## MARTIN® E-Z™ Dry Ingredient Spreader

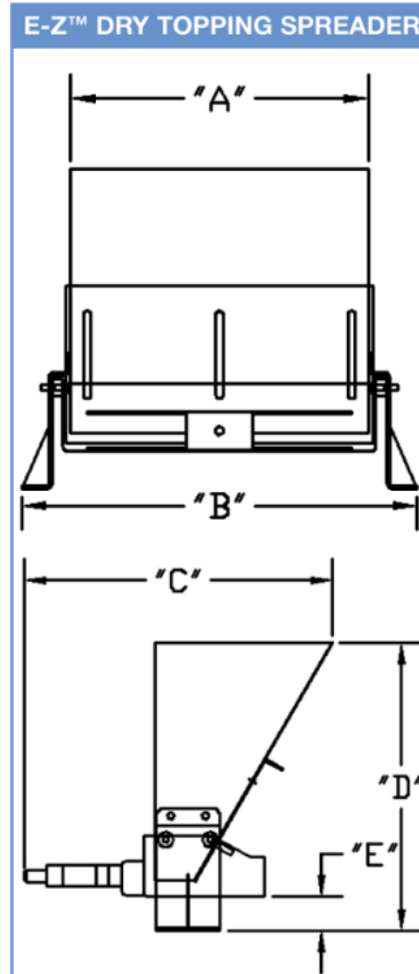

### PHOTOS



MARTIN® E-Z™ Dry  
Ingredient Spreader



MARTIN® E-Z™ Dry  
Ingredient Spreader